

# INSTRUCTION MANUAL

## K4-2 Standalone Access Control

### 1. Packing list

Name	Quantity	Remark
Digital Keypad K4-2	1	
User Manual	1	
Screwdriver	1	
Pastern Stopper	4	6*25mm, used for fixing
Self-tapping Screws	4	4*25mm, used for fixing

Please ensure that all the above contents are correct. If any are missing please notify the supplier of the K4-2.

### 2. Description

The K4-2 is single door multifunction standalone access controller or a Wiegand output keypad or card reader. The K4-2 supports up to 2000 users in either a Card, 4 digit PIN, or a Card + PIN option. The inbuilt card reader supports EM, 125KHZ frequency cards. The K4-2 has many extra features including an anti-magnetic MOS output, lock output current short circuit protection, a Wiegand input and output interface. These features make the K4-2 an ideal choice for door access not only for small shops and domestic households but also for commercial and industrial applications such as factories, warehouses, laboratories, banks and prisons.

### 3. Features

- Mini Access Controller
- Full programming from the keypad
- 2000 users, supports Card, PIN, Card + PIN
- Can be used as a stand alone keypad
- Wiegand 26 input for the connection of an external reader
- External readers can be any make of card reader with a 26 bit output, i.e. HID, Mifare, EM and so on
- Wiegand 26 output for connection to a controller
- Dual K4-2 units can be interconnected and interlocked
- One programmable MOS output
- Adjustable Door Output time, Alarm time, Door Open time
- Anti-magnetic MOS output
- Lock output current short circuit protection
- Easy to install and program
- Built in Tamper Switch for anti-demolition

• 1 •

- Built in buzzer
- LED display the working status
- Two year warranty
- Programmable Fail Safe or Fail Secure Operation

### 4. Specifications

Operating Voltage	12V DC
User Capacity	2000
Keypad	12 keys
Card Type	EM 125 HZ card
Card Reading Distance	3-6 cm
Active Current	<60mA
Idle Current	15 ± 5 mA
Lock Output Load	3A
Alarm Output Load	3A
Operating Temperature	-40~60 °C
Operating Humidity	5%- 95% RH
Adjustable Door Relay time	0 -99 seconds
Adjustable Alarm Time	0- 3 minutes
Wiegand Interface	Wiegand 26 bit
Wiring Connections	Electric Lock, Exit Button, DOTL, External Alarm
Dimensions	50X120X27mm
N. W / G.W	100g / 250g

### 5. Installation

- Remove the back cover from the keypad using the supplied security screwdriver
- Drill 4 holes on the wall for the screws and 1 hole for the cable
- Fix the back cover firmly on the wall with 4 flat head screws
- Thread the cable through the cable hole
- Attach the keypad to the back cover.

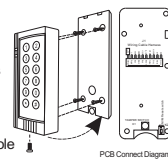

• 2 •

### 6. Wiring

Colour	Function	Description
Green	D0	Wiegand Output D0 (or input from an external reader)
White	D1	Wiegand Output D1 (or input from an external reader)
Grey	Alarm -	Alarm Negative
Yellow	OPEN	Request to Exit Button
Brown	D-IN	Door Contact
Red	12V +	12V + DC Regulated Power Input
Black	GND	0V DC Regulated Power Input
Blue	VSS	Common 0V rail for the REX and the door contact
Purple	L-	Lock Ground/Negative
Orange	L+/Alarm+	Lock and Alarm Positive

### Connection Diagram

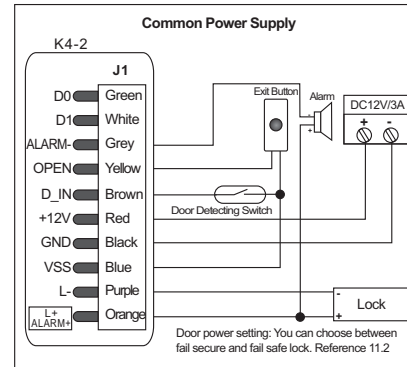

• 3 •

### Special Power Supply

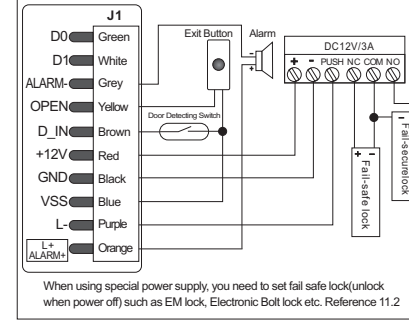

### 7. Interface Circuits

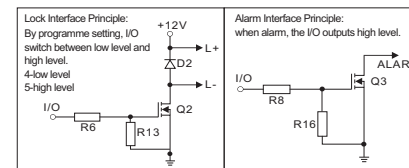

The above diagrams show the output interface circuits. Unlike most lock and alarm outputs which use a relay that can be shocked or magnetized, the K4-2 uses MOS outputs for both the Lock Output on the left and the Alarm Output on the right.

### 8. To Reset to Factory Default

To reset to factory default, power off, press the RESET key (K2) on the PCB, hold it and power on, release it until hear three beeps means reset to factory default successfully. Remarks: Reset to factory default, the user's information is still retained.

• 4 •

### 9. Anti Tamper Alarm

The K4-2 is built-in tamper switch. If the keypad is removed from the cover then the tamper alarm will operate.

### 10. Sound and Light Indication

Operation Status	Red Light	Green Light	Buzzer
Power on	-	Bright	Short Ring
Stand by	Slow Flash	-	-
Press keypad	-	-	Short Ring
Operation successful	-	Bright	Short Ring
Operation failed	-	-	3 Short Rings
Enter into programming mode	Bright	-	Short Ring
In the programming mode	Bright	Bright	-
Exit from the programming mode	Slow Flash	-	Short Ring
Open the door	-	Bright	Short Ring
Alarm	Quick Flash	-	Alarm

### 11. Detailed Programming Guide

#### 11.1 User Settings

To enter the programming mode	* 888888 #	888888 is the default factory master code
To exit from the programming mode	*	
Note that to undertake the following programming the master user must be logged in		
To change the master code	0 New code # New code #	The master code can be 6 to 8 digits long
Setting the working mode: Set valid card only users Set valid card and PIN users Set valid card or PIN users	3 0 #	Entry is by card only
	3 1 #	Entry is by card and PIN together
	3 2 #	Entry is by either card or PIN (default)
To set a user in either card or PIN mode. (Default setting 3 2 #).		

• 5 •

To add a Pin user	1   User ID number   #   PIN   # The ID number is any number between 1 & 2000. The PIN is any four digits between 0000 & 9999 with the exception of 1234 which is reserved. Users can be added continuously without exiting programming mode as follows: 1   User ID no 1   #   PIN   #   User ID no 2   #   PIN   #
To Delete a Pin user	2   User ID number   # Users can be deleted continuously without exiting programming mode
To change the PIN of a PIN user (This step must be done out of programming mode)	*   ID number #   Old PIN #     New PIN #   New PIN #
To add a Card user (Method 1) This is the fastest way to enter cards using ID number auto generation. The ID number will start from 1, if no user has been programmed.	1   Read Card   # Cards can be added continuously without exiting programming mode
To add a Card user (Method 2) This is the alternative way to enter cards using User ID Allocation. In this method a User ID is allocated to a card number. Only one user ID can be allocated to a single card.	1   ID number   #   Card   # The ID number is any digit between 1-2000.
To delete a Card user by card number. Note users can be deleted continuously without exiting programming mode	2   Read Card   #
To delete a Card user by user ID. This option can be used when a user has lost their card	2   User ID   #
To set a Card and PIN user in card and PIN mode ( 3   1   # )	

• 6 •

To Add a Card and Pin user (The PIN is any four digits between 0000 & 9999 with the exception of 1234 which is reserved.)	Add the card as for a card user Press * to exit from the programming mode Then allocate the card a PIN as follows: *   Read card   1234 #     PIN #   PIN #
To change a PIN in card and PIN mode (Method 1) Note that this is done outside programming mode so the user can undertake this themselves	*   Read Card   Old PIN #   New PIN #     New PIN #
To change a PIN in card and PIN mode (Method 2) Note that this is done outside programming mode so the user can undertake this themselves	*   ID number #   Old PIN #     New PIN #   New PIN #
To delete a Card and PIN user just delete the card	2   Read Card   #   or 2   User ID   #
To set a Card user in card mode ( 3   0   # )	
To Add and Delete a Card user	The operating is the same as adding and deleting a card user in 3   2   #
To delete ALL users.	
To delete ALL users. Note that this is a dangerous option so use with care	2   0000   #
<b>To unlock the door</b>	
For a PIN user	Enter the   PIN   then press   #
For a Card User	Read card
For a Card and PIN user	Read card   then enter PIN   #
<b>11.2 Door Settings</b>	
Lock Power Setting & Door relay time setting	
Fail Secure (unlocked when power is on)	*   Master code   #   4   0-99   #   * 0-99 is to set the door relay time 0-99 seconds. 0 for 50mS

• 7 •

Fail safe (unlocked when power is off) This is the factory default, 5 seconds:	*   Master code   #   5   1-99   #   * 1-99 is to set the door relay time 1-99 seconds
<b>Door Open Detection</b> Door Open Too Long (DOTL) warning. When used with an optional magnetic contact or built-in magnetic contact of the lock, if the door is opened normally, but not closed after 1 minute, the inside buzzer will beep automatically to remind people to close the door and continue for 1 minute before switching off automatically.	
<b>Door Forced Open warning.</b> When used with an optional magnetic contact or built-in magnetic contact of the lock, if the door is forced open, or if the door is opened after 20 seconds of the electro-mechanical lock not closed properly, the inside buzzer and alarm output will both operate. The Alarm Output time is adjustable between 0-3 minutes with the default being 1 minute.	
To disable door open detection. (Factory default)	6   0   #
To enable door open detection	6   1   #
<b>Alarm output time</b>	
To set the alarm output time (0-3 minutes) Factory default is 1 minute	9   0-3   #
<b>Keypad Lockout &amp; Alarm Output options.</b> If there are 10 invalid cards or 10 incorrect PIN numbers in a 10 minute period either the keypad will lockout for 10 minutes or the alarm will operate for 10 minutes, depending on the option selected below.	
Normal status: No keypad lockout or alarm (factory default)	7   0   # (Factory default setting)
Keypad Lockout	7   1   #
Alarm Output	7   2   #
<b>To remove the alarm</b>	
To remove the Door Forced Open warning	Read valid card   or Master Code #
To remove the Door Open Too Long warning	Close the door or   Read valid card   or Master Code #

• 8 •

<b>Door Interlock.</b>	
Door interlock disabled	8   0   # (Factory default setting)
Door interlock enabled	8   1   #

### 12. Advanced Applications

**12.1 Operating as a Wiegand Output Reader**  
In this mode the K4-2 supports a Wiegand 26 bit output so the Wiegand data lines can be connected to any controller which supports a Wiegand 26 bit input. See figure 1.

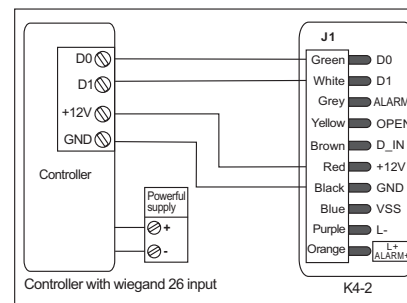

Figure 1

**12.2 Operating as a Controller**  
In this mode the K4-2 supports a Wiegand 26 bit input so an external Wiegand device with a 26 bit output can be connected to the Wiegand input terminals on the K4-2. Either an ID card reader (125 KHZ) or an IC card reader (13.56MHZ) can be connected to the K4-2. Cards are required to be added at the external reader, except where an external EM reader is used, in this case cards can be added at either reader. See figure 2.

**12.3 Two K4-2 units interconnected for a single door**  
In this mode two K4-2 units are used for a single door, one for entry and the other for exit. Either device acts as the controller and reader at the same time. Users can be enrolled on either of the devices. In this mode the user capacity for one door can be up to 4000. The setting of the two K4-2 units must be the same including the master code. See figure 3.

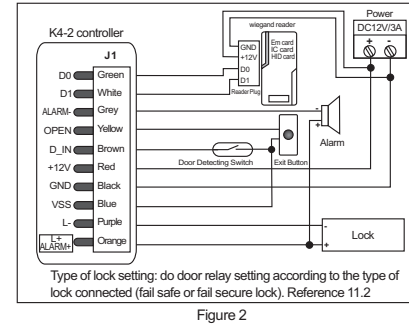

Figure 2

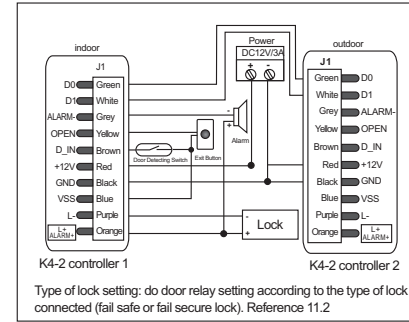

Figure 3

• 10 •

**12.4 Two K4-2 units interconnected & interlocked for 2 doors**  
In this mode two K4-2 units are used for a two doors which are then interconnected and interlocked. In this mode the doors can be interlocked so that when door 1 is open, door 2 cannot be opened, and vice versa. The interlocked function is mainly used in banks, prisons, and other places where a higher level of security is required. See figure 4

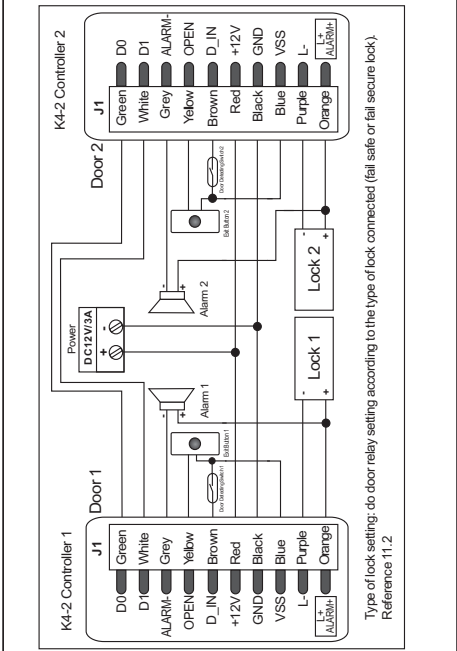

Figure 4

• 11 •